

Art. 30103011 30103013	Type VA31-A101-46 A Pull VA31-A101-46 S Push	Fan diameter 5.1"
--	--	-----------------------------

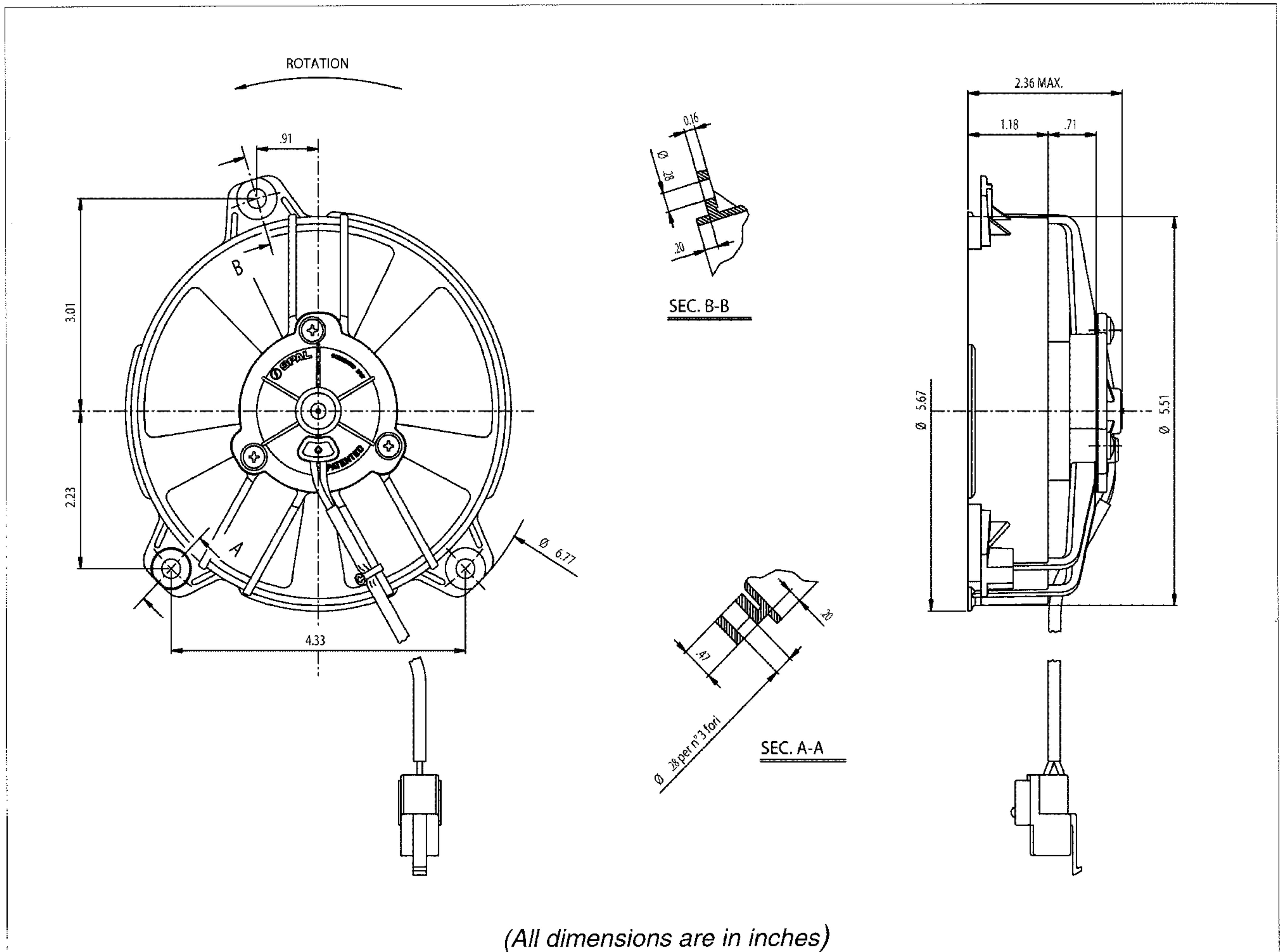

(All dimensions are in inches)

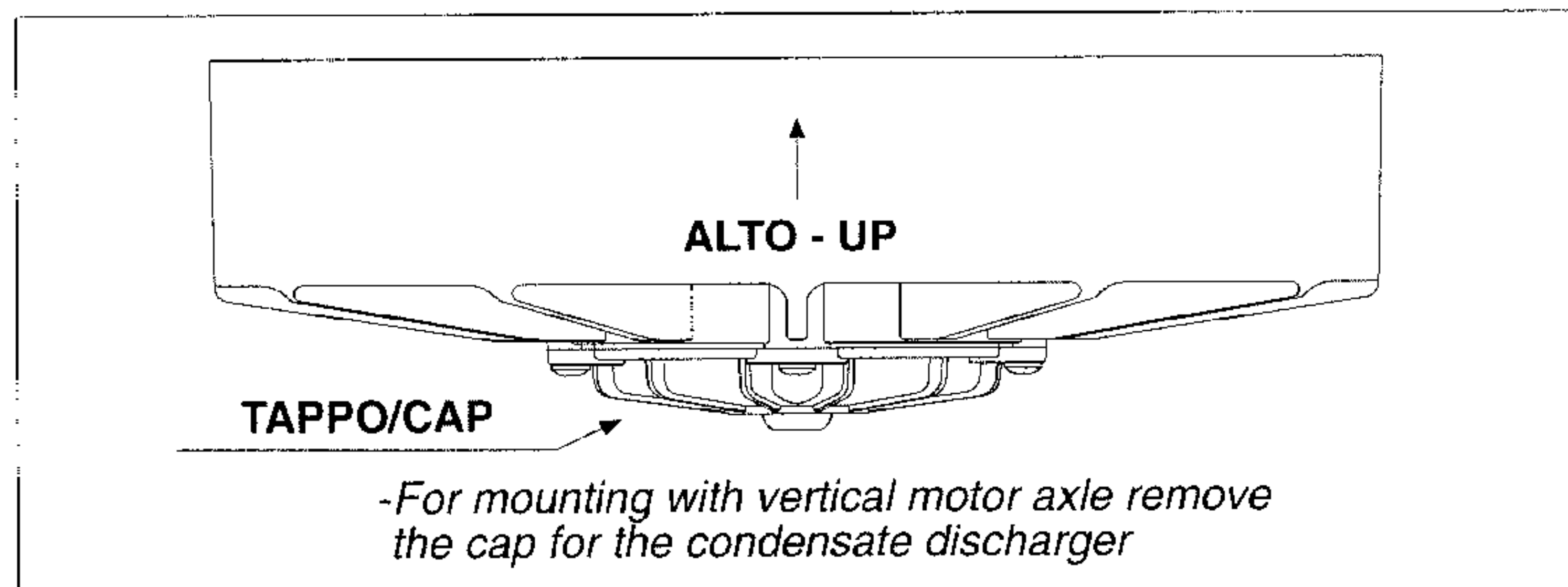

- *Weight .90 lbs. approx.
- *Closed Motor
- *Long Life
- *Available accessories: all the mounting kits

Test voltage 13 V DC

Static pressure	Airflow	Current input
in. H ₂ O	cfm	A
0	313	3.6
0.2	283	3.7
0.4	224	3.9
0.5	195	4.0
0.6	159	4.1
0.8	88.5	4.5

Static pressure: 1 mm H₂O = 0,04 in. H₂O
Airflow: 1 m³/h = 0,59 cfm